

FROM
TEACHERS
FOR
TEACHERS



AI in STEM Education

Understanding, applying, coding

From first steps in AI and data analysis
to smart recycling and machine learning

**Digital teaching resources
for primary and secondary schools**



Learning about artificial intelligence in STEM education can help students to better understand this technology, engage with its applications, and experiment with designing, coding and using AI resources themselves.

For the Science on Stage project "AI in STEM Education", teachers from Germany, Portugal, Turkey and the United Kingdom have compiled a wealth of ideas and resources, presenting their innovative concepts as digital teaching and learning materials. Try out these classroom projects for yourself!

- Free open educational resources
- For all STEM subjects
- Created and approved by teachers
- Teaching units for students aged 6 to 18
- Various cooperation and extension activities
- Translatable in many languages via web browser

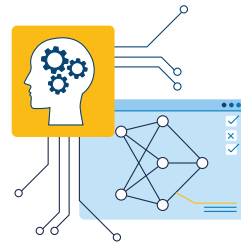

Machine Learning in School

Interactive learning units



EcoKids Teach AI

Making recycling fun with AI superpowers



Recycling Smart

Coding a smart recycling system



First Steps in AI and Data Analysis

How and where is AI being used?

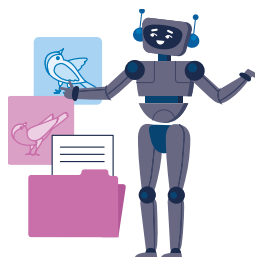

STEM Resources 4.0

Creating educational resources in class

Our digital teaching materials offer the following features:



hands-on learning



videos



coding examples



worksheets and file templates







interactive exercises

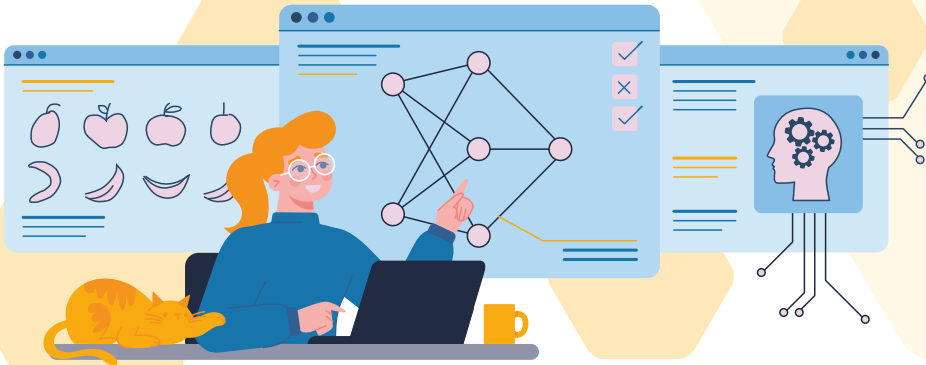

resources for career orientation

Machine Learning in School



- Secondary school (14+) 
- Computer science, mathematics 
- AI, Machine Learning, self-directed learning 
- Computers, laptops, Chromebooks or tablets with internet access 

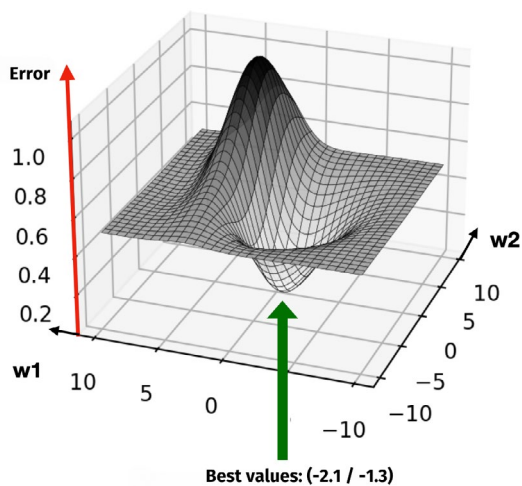

The chapter "Machine Learning in School" explores how artificial neural networks work and what they are used for. The digital learning units are suitable for self-directed learning and aimed at both students and educators who want to familiarise themselves with the topic or expand their existing knowledge. Many sections include interactive examples.



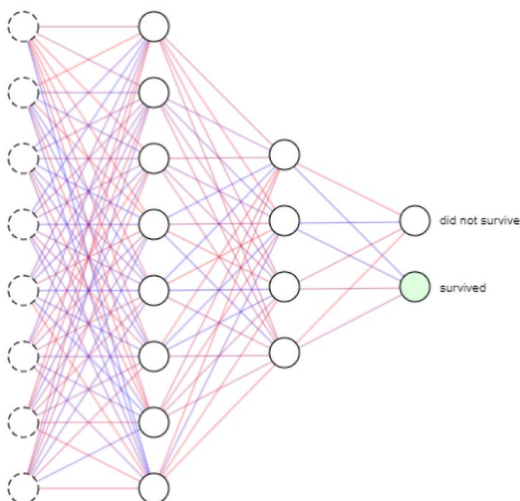

From an introductory example using historical data about Titanic passengers to the experimental generation of a "banana" image using an autoencoder, students will investigate some components and applications of neural networks. They will learn how neural networks make decisions, how inputs are processed into outputs, and how network errors can be minimised.

In addition to units about text, image and audio processing, an online tool is provided where users can input their own data to train and test a neural network.



Discover now!

EcoKids Teach AI

-  Primary school (6–10 years)
-  Primary school, nature and technology, science, computer science
-  AI, Machine Learning, robotics, sustainability, coding
-  Computers with internet access and webcam
 - Block-based programming software (PictoBlox, Scratch, RAISE Playground)
 - VR space (e.g. Frame VR)
 - Google Teachable Machine
 - Educational robots with code cards



In this teaching project, the students become superheroes in a role play with the mission of saving the planet. The teacher gives them the task of researching recycling and learning to train artificial intelligence for a good cause. Throughout the project, the class or group creates a virtual learning space with opportunities for interaction and presentation.

In the next step, the children apply what they have learnt by programming an educational robot's paths to various recycling bins. Using a block-based programming language and a free machine learning tool, they also train an AI to classify recyclable waste.

This project-based learning promotes their digital literacy and computational thinking while also raising awareness of the UN Sustainable Development Goals.

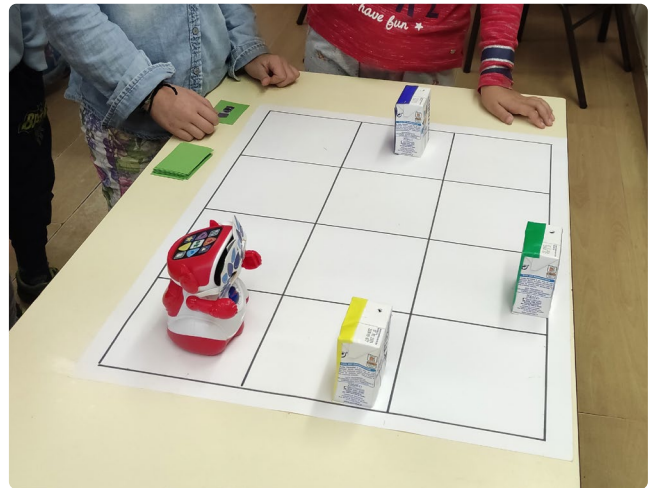

```





when clicked
  turn video on
  set video transparency to 0
  use model https://teachablemachine.withgoogle.com/models/SjLxQNZGsf/
  forever
    wait 2 seconds
    if prediction is paper then
      think Hmm... for 2 seconds
      speak Put in the paper bin.
      say Put in the paper bin!
    if prediction is glass then
      think Hmm... for 2 seconds
      speak Put in the glass bin.
      say Put in the glass bin!
    if prediction is plastic then
      think Hmm... for 2 seconds
      speak Put in the plastic bin.
      say Put in the plastic bin!
  
```

Discover now!

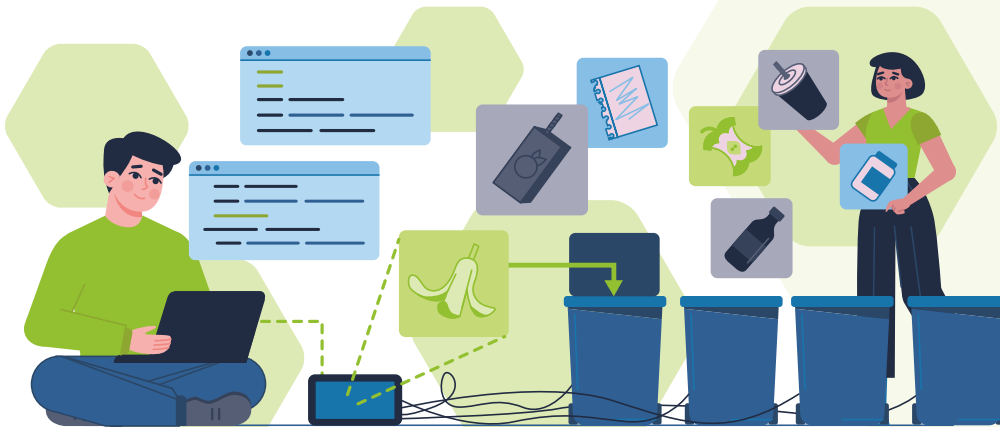

Recycling Smart



- Secondary school (14+) 
- Nature and technology, computer science 
- AI, Machine Learning, coding, robotics, sustainability 
- Raspberry Pi 
- Laptop
- Webcam, servo motors, jumpers, Coral USB Accelerator

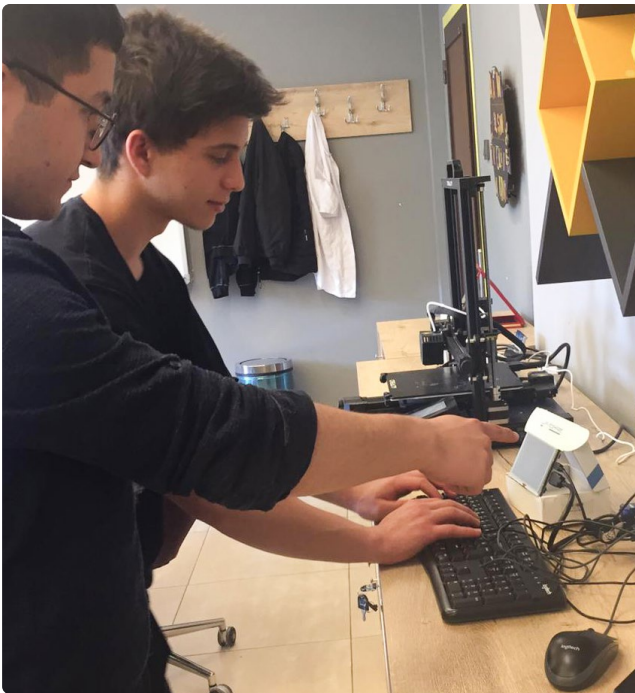

This project uses AI technology for object recognition to motivate students to recycle and strengthen their ability to develop innovative solutions for the challenges of the future.



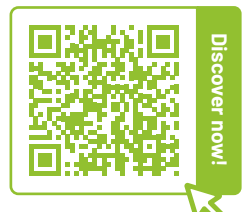
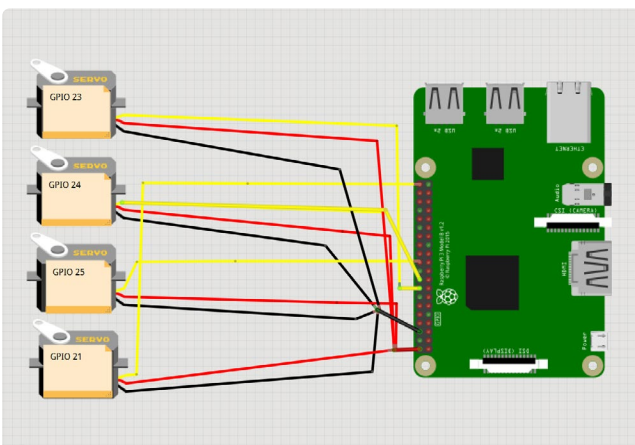

The students build and code a smart waste separation system: when recyclable materials such as glass, plastic or organic waste are held in front of a simple webcam, the object is recognised, and the correct container in a set of recycling bins opens.

The class or project group works with Raspberry Pi and Python. From installing the necessary libraries and writing the code to constructing the bin system with motorised lid opening, the students carry out every step of the project themselves. An already trained machine learning model, code examples, explanations and suggestions for possible extension activities complement this practical teaching material.



Discover now!

First Steps in AI and Data Analysis

-  Primary school, secondary school (10–14 years)
-  STEM, science, primary school, mathematics, computer science
-  AI, Machine Learning, data analysis
-  PCs, laptops, Chromebooks or tablets with internet access
 - Online AI chatbots (Google Gemini, ChatGPT, or other)
 - Online AI image generators (Dall.E, Canva, or other)
 - Zooniverse citizen science portal



This chapter provides simple tools, explanations and resources to introduce the topics of Big Data, artificial intelligence and machine learning. It does not assume any prior knowledge on the part of the teachers.

In the units, students explore current and future applications of AI and machine learning in various contexts. Working in groups, the class analyses supermarket till receipts to draw conclusions about shoppers and approaches the topic of Big Data through a discussion about customer loyalty cards. In another activity, the students roll dice to generate their own data and learn how to process this data using a spreadsheet. They also gain practical experience with various generative AI tools for text and image creation. In this way, the project also offers the opportunity to discuss the ethical aspects of artificial intelligence.

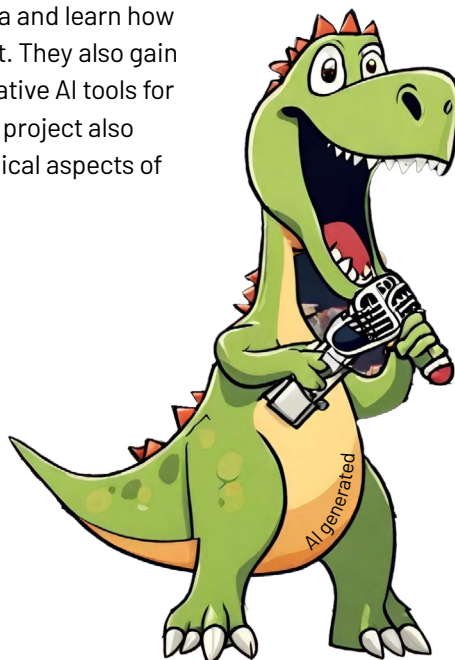

Discover now!



Supermarket

Receipt ID: 1244660000000
 Date: 12/5/23
 Time: 11:23
 Cashier ID: 0024884
 Loyalty Card: 1234 5678 9012 3456

ITEM	TOTAL
Wholemeal Bread x 2	£2.30
50:50 Sliced Bread	£1.45
Orange Diluting Juice 1Lt	£2.55
Size 3 Nappies (24 pack)	£5.60
Toothpaste (Age 6–9)	£1.95
Apples x 2 packs	£2.50
Satsumas x 2 packs	£3.20
Bananas x 10	£2.10
Coffee 1kg	£5.60
Pizza 2 x large Margarita	£4.90
Pizza 1 x large Pepperoni	£2.75
24 pack Toilet Roll	£5.50
Carrots 1kg	£1.80
Baking potatoes (6 pack)	£1.70
Shreddies (XL pack)	£4.00
6 Chicken Breasts	£5.90
Beef mince 1kg	£3.60
4 pack Tinned Tomatoes	£4.20
8 pack Raspberry Jelly	£4.60
Sliced cheese x 2 packs	£4.00
Sliced ham x 2 packs	£3.90
Cat Litter 25kg	£14.85
Size 6 Pull Up Nappies (12 pack)	£2.75
Curry Sauce 300mls	£2.85
Spaghetti 2 x 500g	£2.10
Washing pods XL pack	£11.50
Dishwasher Tablets XL pack	£10.90
Chocolate biscuits – Twin pack	£2.55
TOTAL	£121.60

PAID BY CARD

STEM Resources 4.0

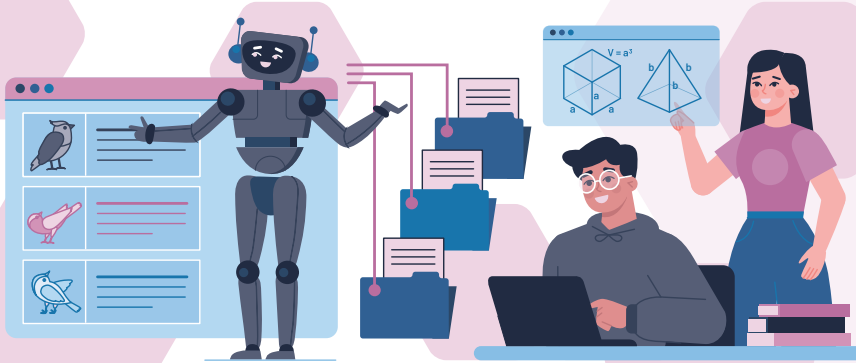

Secondary school (13–16 years)

Natural sciences, biology, chemistry, mathematics, computer science

AI, Machine Learning, coding, STEAM

Block-based programming software (PictoBlox)

Computers with internet connection and webcam

Optional: 3D printer

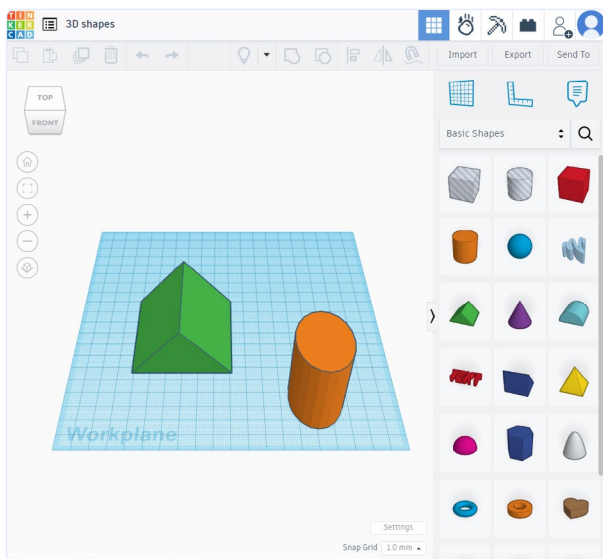

These interdisciplinary teaching units are based on methods of inquiry-based learning and pair programming. The students are encouraged to take control of their learning process and use AI to design their own digital educational resources for various STEM subjects.

In the material, three sample units are presented: Students work in pairs to explore pH value, characteristics of local animals, or geometric solids. Using PictoBlox, a visual programming platform based on Scratch, they train machine learning models, create their learning programme, and test the results. The units are supplemented by step-by-step instructions for the individual group work phases, video tutorials and rubrics for evaluation.

This process can be adapted to any teaching topic.

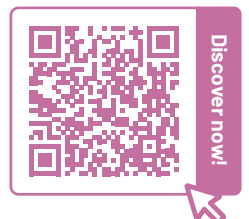
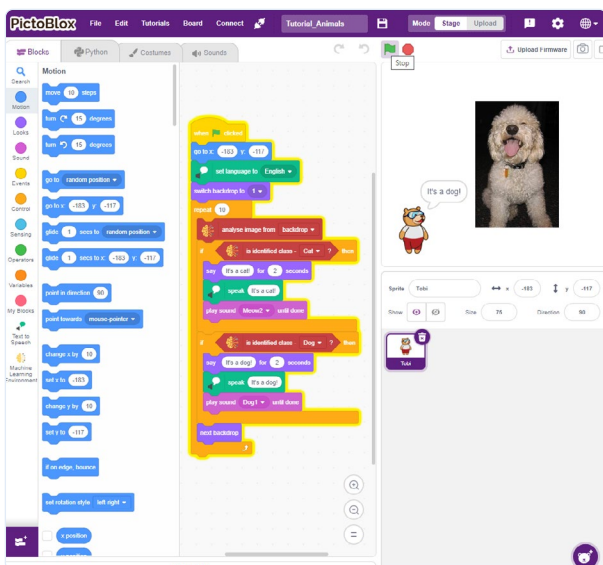



Have our AI teaching materials inspired you, or have you already developed an exciting project yourself? We invite students and their teachers to apply for our **AI Challenge** with an innovative approach to using AI by 23 February 2025. The winning teams will be selected at the Berlin finals in June 2025. Learn more about the competition on our website and participate!



Through the **"Coding for our Future"** programme, Science on Stage offers grants for teacher training activities on topics such as AI, cloud computing, the Internet of Things, automation, and simulation. Learn more about this funding opportunity on our website.



Science on Stage offers teaching materials developed by European STEM teachers for teachers. All materials are free open educational resources and can be downloaded here: www.science-on-stage.eu/teachingmaterials



Science on Stage Germany
Am Borsigturm 15
13507 Berlin · Germany
Phone +49 30 400067-40
info@science-on-stage.de
www.science-on-stage.de

**Learn more about Science on Stage Europe –
The European Network for Science Teachers**



Supported by



A project by



Main supporter of Science on Stage:

